



FLAIR

STRETCH
FABRIC

WALL SYSTEM



CREDENCE
We The Trust

World Most trusted

100 % Made In India Brand



BENEFITS

- Excellent Sound absorption (NRC 0.7-0.95)
- Excellent decorative
- Multiple fabric option
- Customization available

AREA OF APPLICATION

- Auditoriums, Conferences Rooms
- Seminar Hall, Libraries, Indoor Stadium
- Cinema Hall, Home Theater
- Studio , Study room, Pubs

TECHNICAL DATA



BEST ACOUSTIC
PERFORMANCE



EASY TO CLEAN



FIRE RETARDANT



HUMIDITY
RESISTANCE



MULTIPLE
COLOUR OPTION

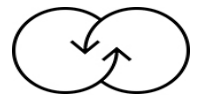

RECYCLABLE

TECHNICAL DATA

Size	Customized
Thickness	50mm – 100mm
Colour	Multiple colour range of fabric
NRC	0.7 - 0.95
Framework	Aluminium/GI
Stretching	UPVC Grippers
Absorption Material	Polyester wadding/Glass wool
Optional framework	Wood wool board/Perforated ply
Fire Resistance	Class A

COLOUR OPTIONS

➤ MULTIPLE COLOUR RANGE OF FABRIC

INSTALLATION

OPTION- INSTALLATION

FLAIR Acoustic Wall System can be affixed to the wall, as follows:

1. Install the GI/ Aluminum framework on the wall 600 mm center to center. (As Shown in Diagram 1)

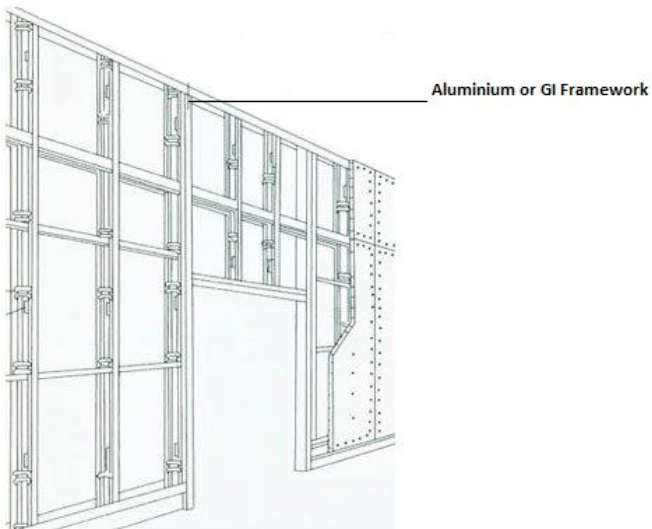

Diagram 1

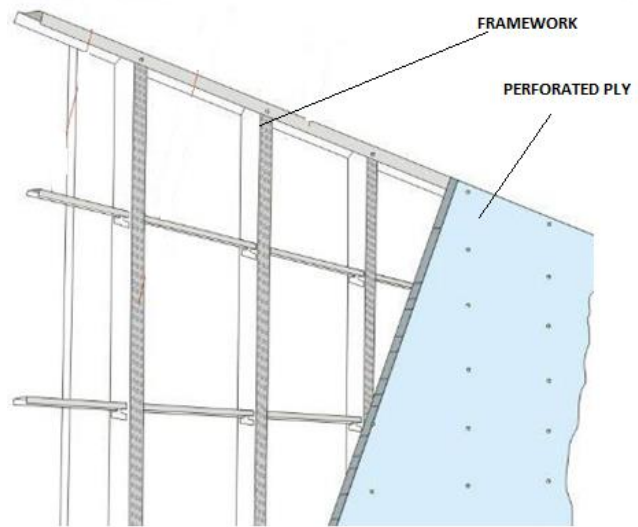

Diagram 2

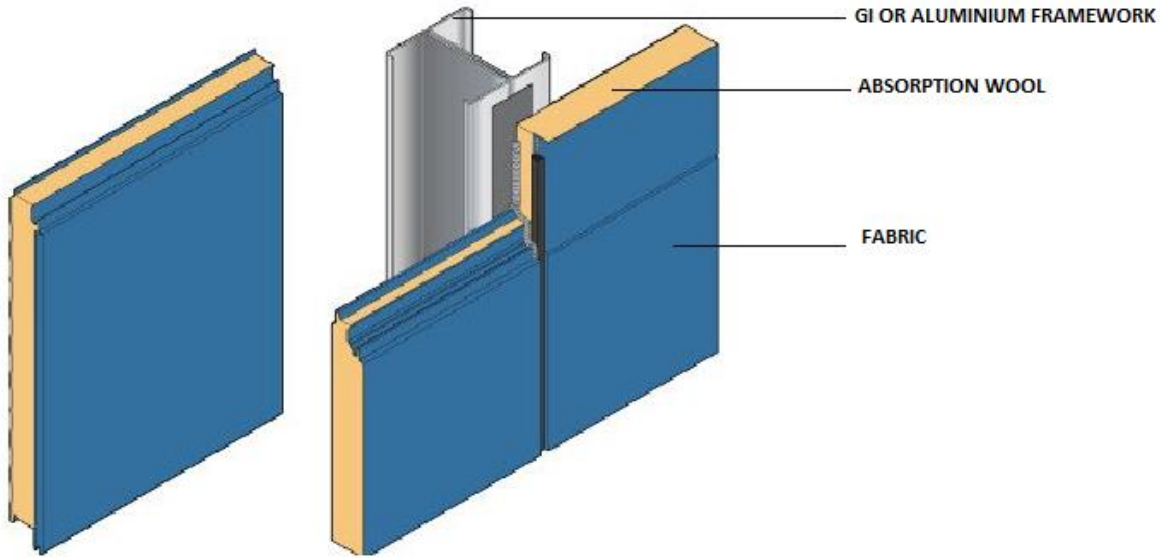

Diagram 3

2. Fix the perforated ply or wood wool panel on the GI/Aluminum framework.
3. Fill the cavity between the wall & ply/wood with the absorption wool. (As Shown in Diagram 3)
4. Stretch the fabric with the help of UPVC grippers.

APPLICATION & REQUIRED VOLUME



FOR COMMERCIAL SPACE

35-45 % Wall paneling of FLAIR is sufficient for a quiet surrounding

FOR OFFICE & COMMERCIAL SPACE

25-35 % Wall paneling of PINE is sufficient for a noise free environment of work place to enhance the work capability



FOR HOME THEATER

45-65 % covering is sufficient for the small home theater, Studio to maintain good sound effects within the

FOR AUDITORIUMS & CINEMA HALLS

65-90% coverage of the PINE wall panel is sufficient to maintain the required reverberation time



MAINTENANCE

THE MAINTENANCE INSTRUCTION & RECOMMENDATIONS TO REMOVE DUST, PEN MARKS, STAINS ARE AS FOLLOWS –

- ✓ USE SMOOTH BRUSH OR VACUUM CLEANER FOR ANY TYPE OF DUST OR DIRT PARTICLES. ENSURE TO CLEAN IN ONE DIRECTION ONLY.
- ✓ USE FRESH GOOD QUALITY CLEANER FOR REMOVING PEN MARKS OR SMUDGES. ENSURE TO CLEAN IN ONE DIRECTION ONLY.
- ✓ USE VOLATILE SOLVENT BASED CLEANER FOR OIL BASED STAINS. ENSURE TO CLEAN IN ONE DIRECTION ONLY.

WARRANTY

- ✓ 2 YEARS WARRANTY FOR CREDENCE FLAIR WALL SYSTEM

* PLEASE REFER TO WARRANTY DOSSIER FOR WARRANTY CLAUSES & TERMS

CONTACT US

Call us: +91-120-5105463
+91-99900 49959

Email: info@credenceindustries.com , sales@credenceindustries.com

